

SFOGLIATRICI • SHEETERS • LAMINOIRS • LAMINADORAS



SF450B • SF450BV • SF500B • SF500BV • SF500 • SF500V • SF600 • SF600V

- Struttura in acciaio verniciato (o in acciaio inox su richiesta)
- Protezioni antinfortunistiche secondo la normativa CE
- Regolazione precisa dello spessore della sfoglia mediante scala graduata
- Raschiatori facilmente rimovibili
- Tappeti a velocità variabile per ottenere uniformità nella sfoglia
- Piani rialzabili per limitare al massimo l'ingombro quando la macchina non è in uso
- Inversione del senso di laminazione dei tappeti mediante joystick e/o pedale
- *Optional:* gruppo di taglio per croissant, pizzette etc. e velocità variabile dei tappeti

- Painted steel structure (on request stainless steel is also possible)
- Safety covers device in accordance with CE regulations
- Precise regulation on thickness of sheet by a graded scale
- Scrapers can be removed very easy
- Variable speed between infeed and discharge belts assure regular dough sheet
- Belts can be raised when the machine is not in use to obtain more free space
- Reversal rolling belts by joystick and/or by pedal
- *Optional:* cutting unit for croissants, pizza etc. and variable speed belts

- Structure en acier verni (ou sur demand en acier inox)
- Protections contre les accidents conformes aux lois CE
- Reglage précis du épaisseur du pate feuilletée par une échelle graduée
- Racleur facilement amovible
- Tapis avec vitesse variable pour assurer l'uniformité de la pate feuilletée
- Table de travail remontable pour réduire l'encombrement
- Inversion de laminage par joystick ou par pedale
- *Optional:* dispositif de decoupe pour croissants, pizza etc. et tapis a vitesse variable

- Estructura de acero barnizado (o a petición en acero inoxidable)
- Protecciones contra infortunios de acuerdo con la regulación CE
- Regulación precisa del espesor final de la hojaldre por medio de una escala graduada
- Raspadores pueden ser muy fáciles quitado
- Tapetes a velocidad variable aseguranos la precisión del espesor final de la hojaldre
- Sistema de alzamiento de las mesas por obtener más espacio libre
- Inversión de laminación por medio de joystick y/o pedal
- *Optional:* dispositivo de corte para croissant, pizza etc. y velocidad de las cintas variable

CARATTERISTICHE TECNICHE/TECHNICAL FEATURES/CARACTERISTIQUES TECHNIQUES/CARACTERISTICAS TECNICAS

CODICE MACCHINA/MACHINE CODE/CODE MACHINE/ CODIGO MAQUINA	SF450B	SF450BV	SF500B	SF500BV	SF500	SF500V	SF600	SF600V
TIPO/TYPE/TIPO	BENCH	BENCH	BENCH	BENCH	A-FRAME	A-FRAME	A-FRAME	A-FRAME
DIAMETRO CILINDRI/CYLINDERS DIAMETER/CYLINDRES DIAMÈTRE/ DIÁMETRO CILINDROS	60 mm	60 mm	60 mm	60 mm	60 mm	60 mm	70 mm	70 mm
LARGHEZZA TAPPETI/BELT WIDTH/LARGER TAPIS/ ANCHURA TAPETES	450 mm	450 mm	500 mm	500 mm	500 mm	500 mm	600 mm	600 mm
LUNGHEZZA PIANI/LENGHT BELTS/LONGUEUR TAPIS/ LARGO TAPETES	500/700 mm	500/700 mm	850/1000 mm	850/1000 mm	850/1000/ 1200 mm	850/1000/ 1200 mm	850/1000/1200/ 1400/1600 mm	850/1000/1200/ 1400/1600 mm
VELOCITÀ TAPPETO IN USCITA/EXIT BELT-VITESSE SPEED TAPIS-VELOCIDAD DE SORTIE/TAPETES EN SALIDA	30 m/min	MIN 3 m/min MAX 33 m/min	30 m/min	MIN 3 m/min MAX 33 m/min	30 m/min	MIN 3 m/min MAX 33 m/min	MIN 4 m/min MAX 36 m/min	MIN 4 m/min MAX 36 m/min
APERTURA CILINDRI/ROLLER GAP/OUVERTURE CYLINDRES/ APERTURA CILINDROS	0-35 mm	0-35 mm	0-35 mm	0-35 mm	0-35 mm	0-35 mm	0-40 mm	0-40 mm
POTENZA MOTORE/MOTOR POWER/PUISSANCE MOTOR/ POTENCIA MOTOR	0,50 kW	0,50 kW	0,50 kW	0,50 kW	0,50 kW	0,50 kW	0,75 kW	0,75 kW
PESO/WEIGHT/POIDS/PESO	90 Kg	90 Kg	140 Kg	140 Kg	170 Kg	170 Kg	245 Kg	245 Kg

SFOGLIATRICI • SHEETERS • LAMINOIRS • LAMINADORAS

➤ SF450B | SF450BV

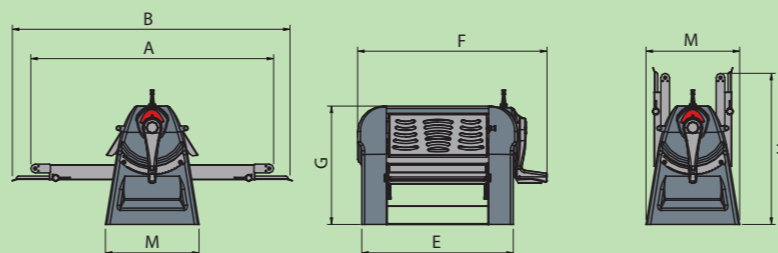

➤ SF500B | SF500BV

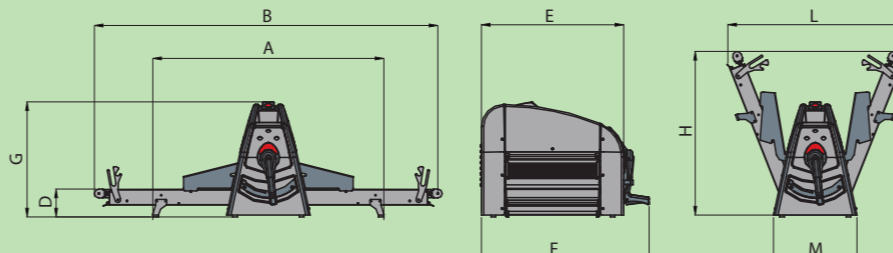

➤ SF500 | SF500V

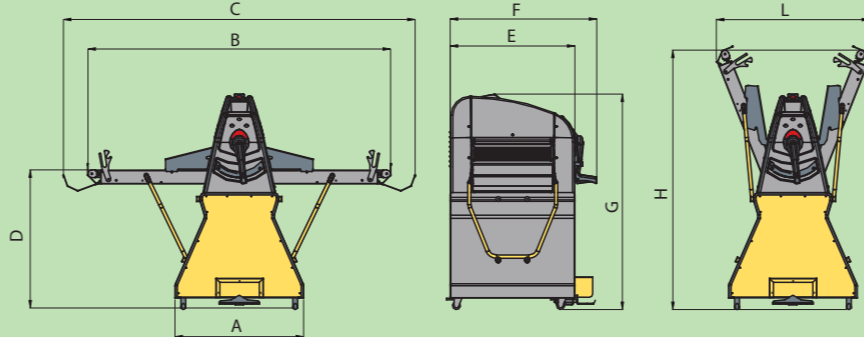

➤ SF600 | SF600V

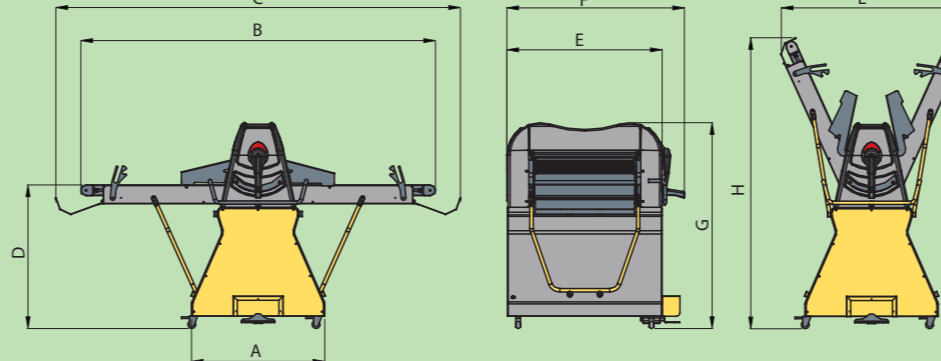

DIMENSIONI/DIMENSIONS/DIMENSIONS/DIMENSIONES

	A	B	C	D	E	F	G	H	L	M
SF450B-500	1120	1280	-	-	700	870	540	690	-	430
SF450B-700	1520	1680	-	-	700	870	540	890	-	430
SF500B-850	1250	1860	2110	150	770	910	620	880	950	455
SF500B-1000	1250	2160	2410	150	770	910	620	1030	1000	455
SF500-850	800	1860	2110	880	770	910	1335	1620	950	-
SF500-1000	800	2160	2410	880	770	910	1335	1760	1020	-
SF500-1200	800	2560	2810	880	770	910	1335	1920	1180	-
SF600-850	800	1860	2190	900	920	1065	1225	1619	960	-
SF600-1000	800	2160	2490	900	920	1065	1225	1757	1100	-
SF600-1200	800	2560	2890	900	920	1065	1225	1940	1250	-
SF600-1400	800	2960	3290	900	920	1065	1225	2123	1400	-
SF600-1600	800	3480	3810	900	920	1065	1225	-	-	-



FLAMIC srl
Via dell'Artigianato, 5 - 36035 Marano Vic.no (VI) Italy
Tel.+39 0445 575182 Fax +39 0445 501743 info@flamic.it

www.flamic.it



SFOGLIATRICI • SHEETERS • LAMINOIRS • LAMINADORAS

YOUR SOLUTION

SF450B • SF450BV • SF500B • SF500BV • SF500 • SF500V • SF600 • SF600V



www.flamic.it

OPTIONAL

- stazione di taglio
- cutting station
- unite de coupe
- estation de corte

- variatore di velocità
- speed variator
- variateur de vitesse
- variador de velocidad

➤➤➤ SFOGLIATRICI • SHEETERS • LAMINOIRS • LAMINADORAS



➤ SF600V



➤ SF600



➤ SF500 | SF500V



➤ SF500B | SF500BV



➤ SF450B | SF450BV



flamic
BAKERY AND PASTRY EQUIPMENT

www.flamic.it

YOUR SOLUTION